

ILFORD 1050 RC

PRINT DRYER FOR HIGH QUALITY BLACK AND WHITE
PRINT DRYING. FROM SERIAL NUMBER 1C51746



SAFETY PRECAUTIONS

Your photographic equipment is powered by mains electricity, and is designed to comply with international electrical safety standards. However, basic safety precautions must always be followed when operating electrical equipment, including the following:

- 1 Read and understand all instructions.
- 2 Certain internal parts of the equipment become very hot with continuous use. Take care to avoid burns.
- 3 Do not operate equipment that has been dropped or damaged, or has damaged electrical leads. Have the equipment examined by qualified personnel.
- 4 Do not allow any electrical lead to touch hot surfaces.
- 5 Avoid scuffing any electrical leads that hang over the edge of working surfaces. Ensure the leads are arranged such that they cannot be pulled or tripped over (this applies also to any extension leads).
- 6 Ensure extension leads are of a suitable current rating to prevent the lead overheating.
- 7 Always unplug the equipment when it is not in use. Never pull plugs out by the lead.
- 8 Install the equipment on a normally dry surface.
- 9 Do not dismantle the equipment unless you are qualified to do so. Incorrect assembly can cause hazards both to yourself and to the equipment.
- 10 Always obey local codes of practice, particularly when installing equipment.

Do not destroy these instructions

CONTENTS

	Page
1 Introduction	3
2 Controls and indicators	5
2.1 'Power' light	5
2.2 Dryer control	5
2.3 Temperature control	5
3 Installation	7
3.1 Print receive tray	7
3.2 Location	7
3.3 Electricity supply	7
3.4 Removing yellow transit wedges	7
4 Drying prints	8
5 Switching off	9
6 Cleaning and simple repairs	10
6.1 Cleaning the front roller assembly	10
6.2 Replacing a mains fuse	10
6.3 Replacing a roller tension spring	11
6.4 Removing rear rollers/adjusting print exit guide	11
7 Fault finding	14
7.1 Safety feature	14
8 Specification	17
Insert	
Wall chart	

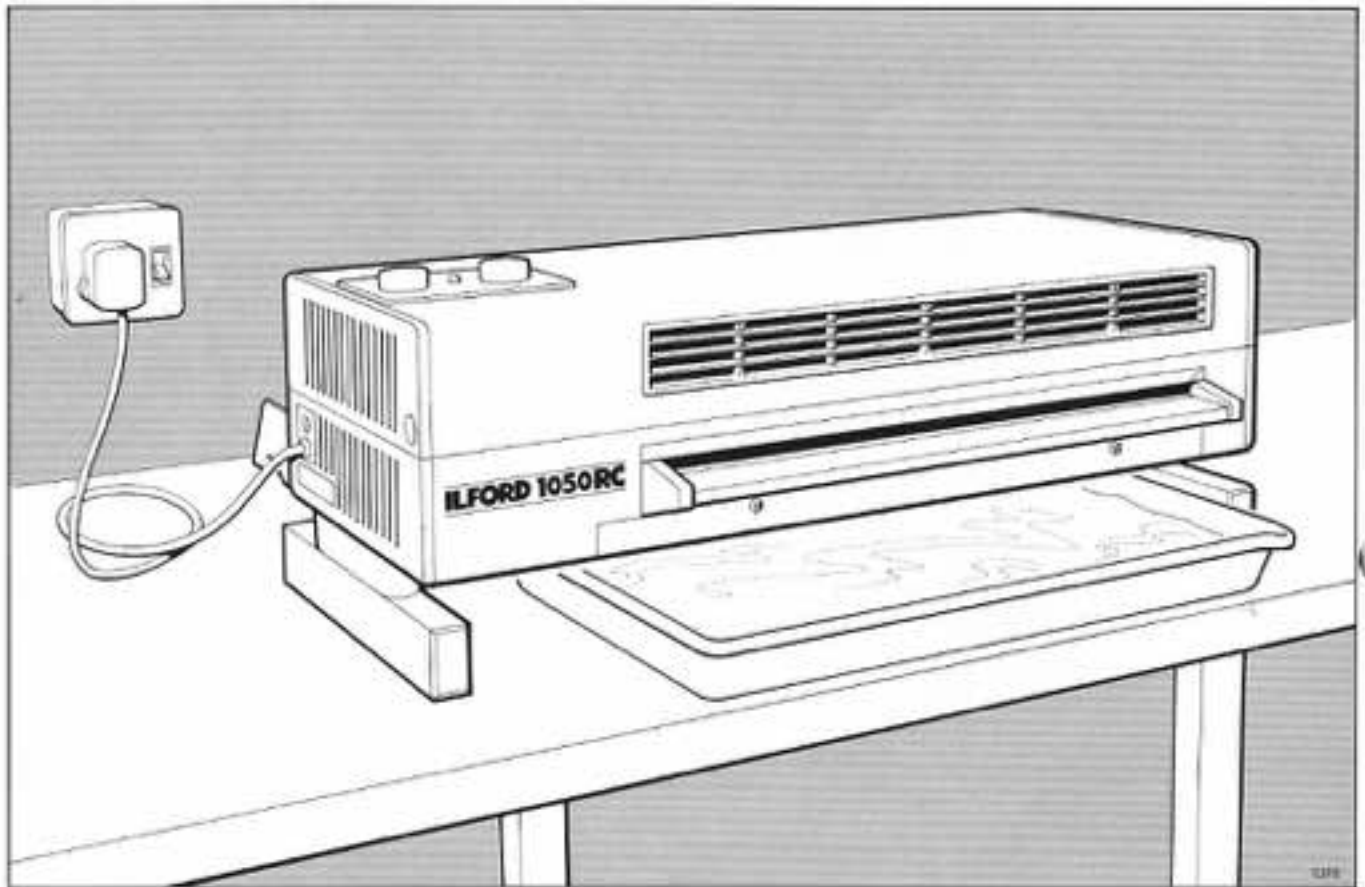

ILFORD 1050RC dryer

Figure 1.1

1 INTRODUCTION

The ILFORD 1050RC dryer (see figure 1.1) is designed to dry ILFORD black and white resin coated papers to a very high standard. The dryer will dry up to 480 20.3x25.4cm (8x10 inches) prints per hour, and has a maximum feed width of 50.8cm (20 inches). The ILFORD 1050RC dryer plays a very important part in the ILFOSPEED dish processing system.

For uniform drying and greater efficiency, prints are dried by infra-red, fan assisted heaters. Paper is transported through the dryer at a constant speed and the output of the heaters can be adjusted over a wide range of temperatures to give optimum results.

This manual gives full instructions for installing and operating the ILFORD 1050RC dryer. For ease of description, it is assumed the left and right sides of the dryer are determined when facing the dryer at the paper feed (front) end.

Wall chart

A wall chart is supplied with this manual, and summarises the regular operating procedures.

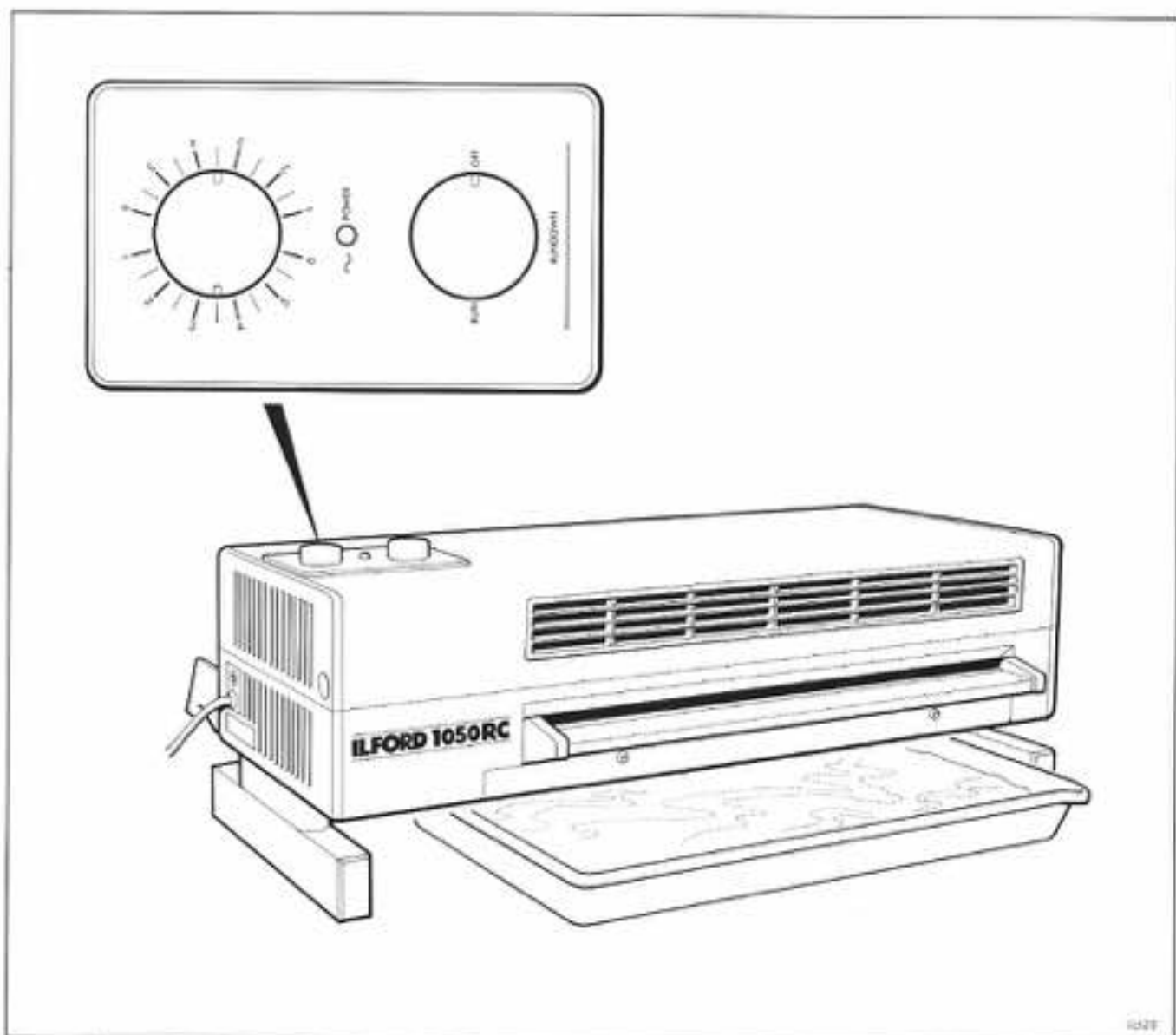

Controls and indicators

Figure 2.1

2

CONTROLS AND INDICATORS

See figure 2.1.

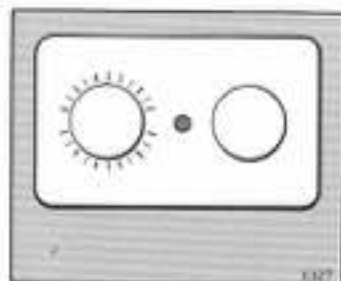

- 2.1 'Power' light
Illuminates when the dryer is switched on.

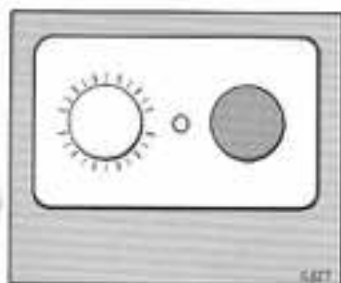

- 2.2 Dryer control
The dryer control has three positions:

Position 'off'
The dryer is switched off.

Position 'rundown'
Power is supplied to the fans and main drive but not to the heaters.

Note

It is important to use this position for 2 minutes before switching the dryer off to prevent excessive heat retention in the rubber rollers and, therefore, extend the life of the rollers.

Position 'run'
For drying sheets.



- 2.3 Temperature control
The temperature control is adjustable over the range 1 (minimum) to 6 (maximum).

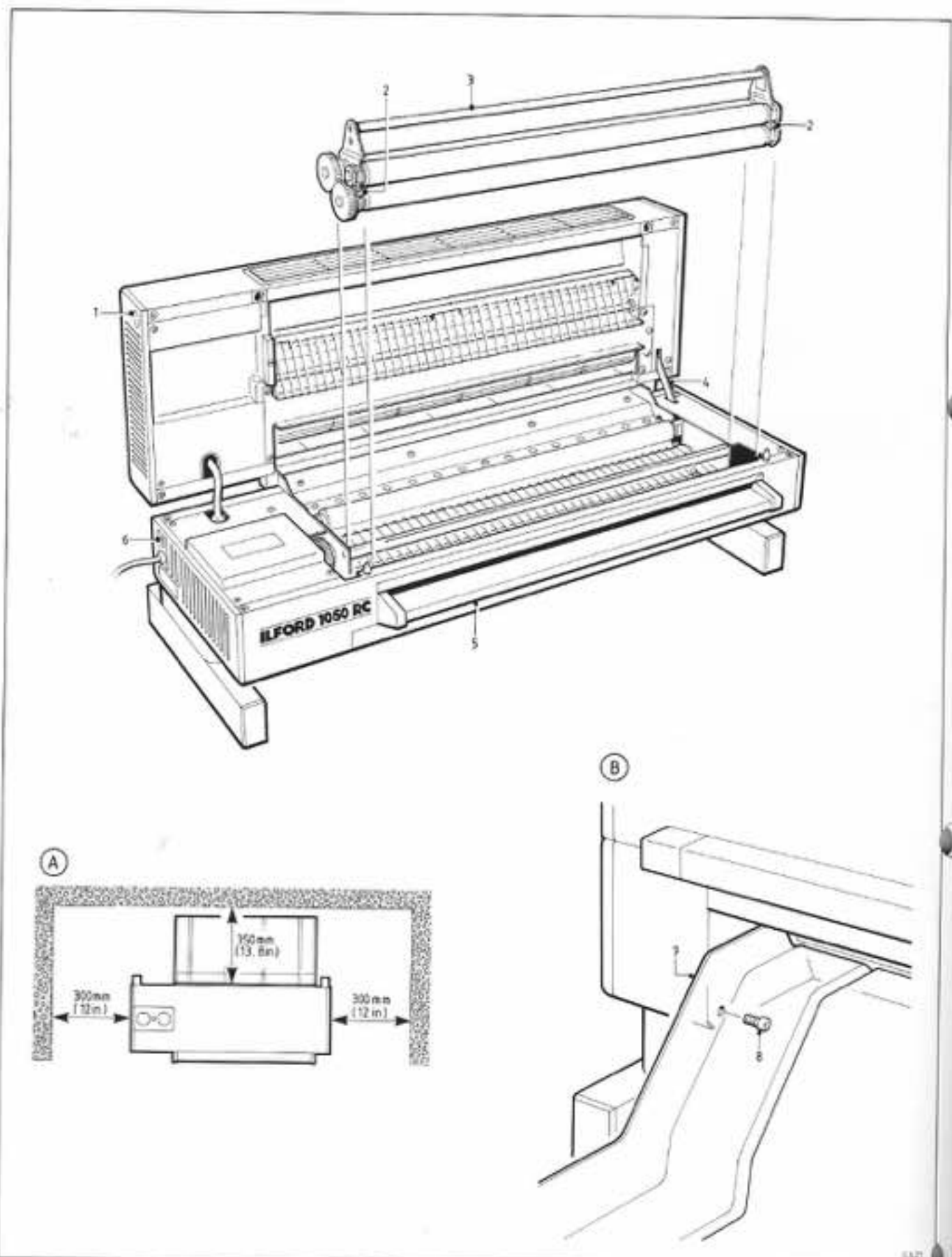

Installation

Figure 3.1

3 INSTALLATION

Figure 3.1

- 1 Release button
- 2 Yellow transit wedge
- 3 Four-roller assembly
- 4 Restraining arm
- 5 Feed tray
- 6 Mains fuse
- 7 Print receive tray
- 8 Pan head screw

See figure 3.1.

3.1 Print receive tray

Secure the tray with the screws supplied as shown in detail B.

3.2 Location

Position the dryer on a firm bench or table at a convenient working height. The dimensions shown in detail A are minimum requirements to allow for adequate air circulation and for the print receive tray. Position the wet print dish under the dryer.

3.3 Electricity supply

Connect a standard plug of at least 10 amp rating to the end of the mains cable as follows:

- a Brown wire to live pin (marked L).
- b Blue wire to neutral pin (marked N).
- c Green/yellow wire to earth pin (marked E or \downarrow).

3.4 Removing yellow transit wedges

CAUTION

To enable the dryer to operate correctly, it is important to remove the two yellow transit wedges prior to use.

Press the release button on the left hand side of the dryer and open the dryer until the lid is held securely by the restraining arm. Lift the four-roller assembly away, and rest the assembly on a bench. Pull out the two yellow transit wedges, refit the roller assembly and close the dryer.

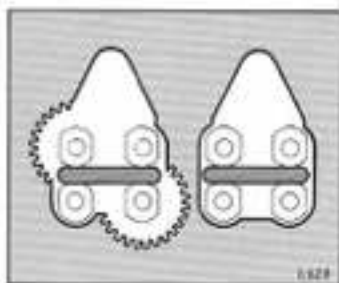

4

DRYING PRINTS

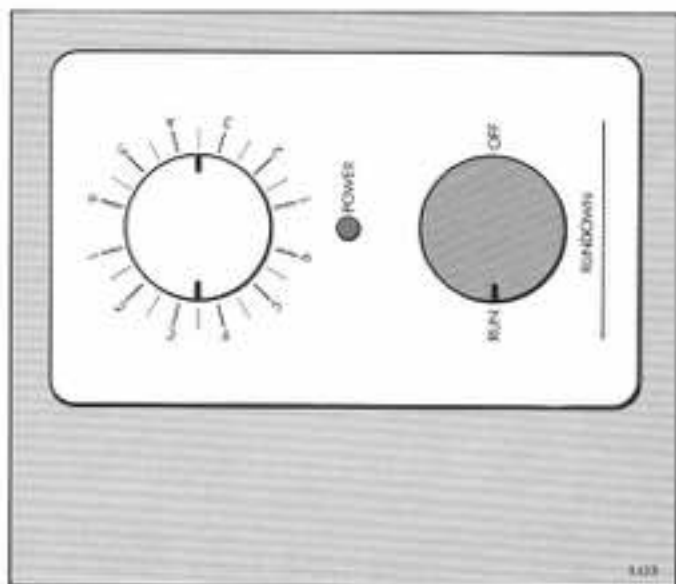

- 1 Fill the wet-print dish with enough cold water to cover the washed prints.

Connect the dryer to the electrical mains supply. Turn the dryer control to 'run'.

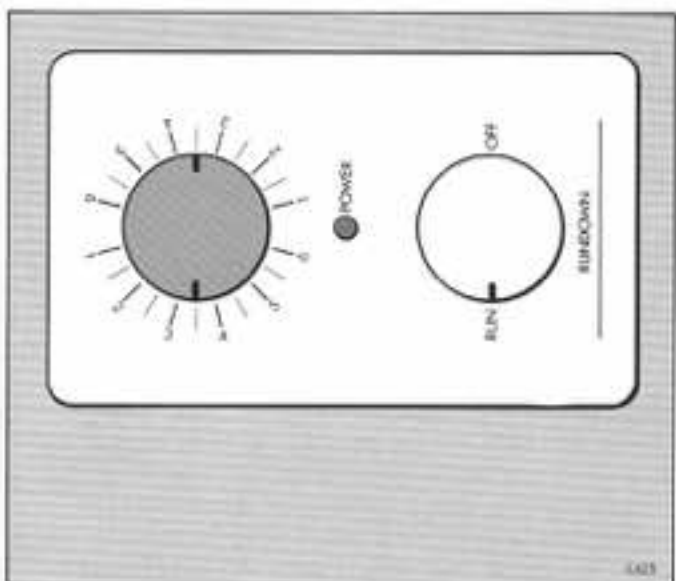

- 2 Turn the temperature control to the required setting. Initially, try a mid-point setting. Allow about 2 minutes for the dryer to warm up.

During this time transfer the washed prints to the wet-print dish.

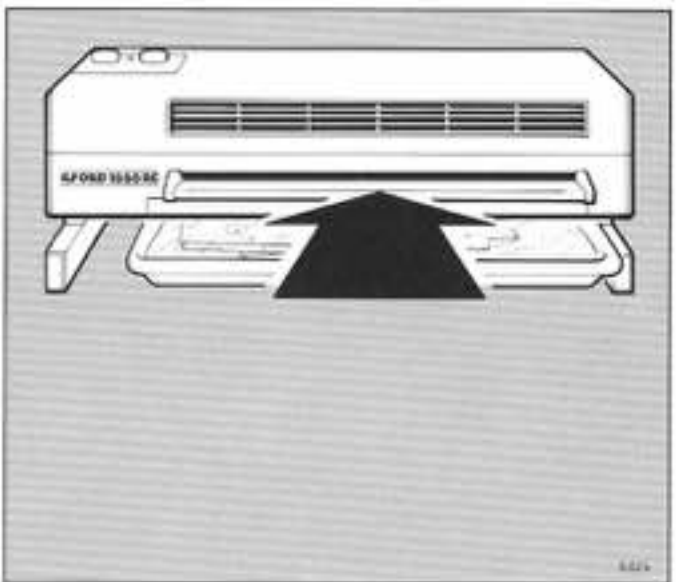

- 3 Feed prints emulsion side up. Ensure prints are fed squarely. Feed small prints with the short edge leading. Do not overlap one print with another - allow 2 seconds between the trailing edge of one print and the leading edge of the next.

5 SWITCHING OFF

- 1 Turn the dryer control to 'rundown'. Allow the dryer to cool for 2 minutes.

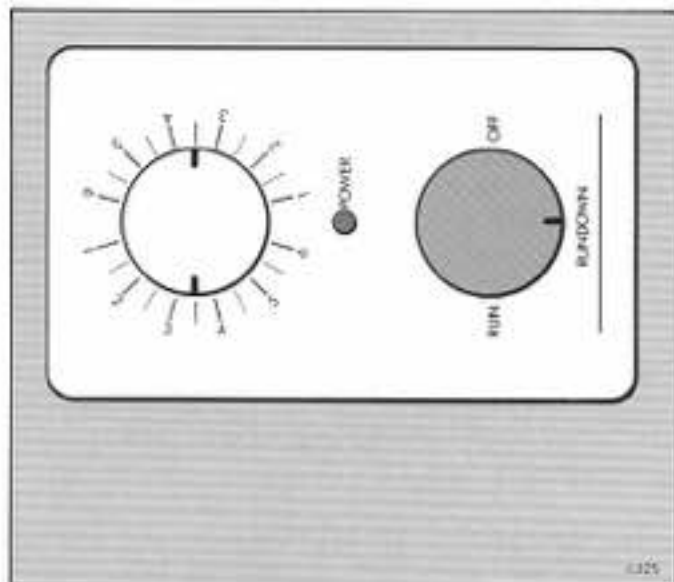

- 2 Turn the dryer control to 'off'. Switch off the electrical mains supply.

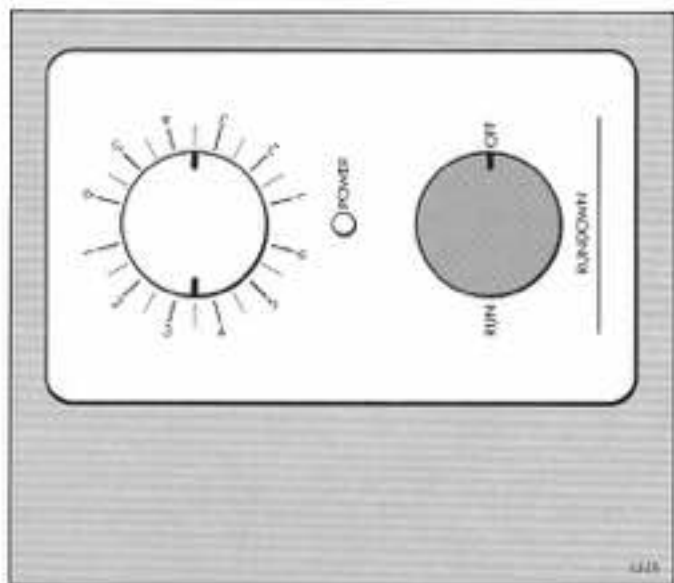

6

CLEANING AND SIMPLE REPAIRS

Cleaning is the only regular maintenance required to maintain the drying quality of the ILFORD 1050RC dryer.

- 1 Change the water in the wet-print dish daily or more frequently if necessary.
- 2 Occasionally wipe the outside of the dryer with a damp cloth.

6.1 Cleaning the front roller assembly See figure 3.1.

WARNING

On no account allow water to enter areas of the dryer containing electrical components.

If the four-roller assembly at the front of the dryer becomes contaminated, remove and clean it as follows:

- 1 Isolate the dryer from the electrical mains supply (see section 5).
- 2 Press the release button and open the dryer until the lid is held securely by the restraining arm.
- 3 Remove the four-roller assembly.
- 4 Clean the rollers with a soft, lint free cloth and warm water. More stubborn deposits on metal and plastic surfaces can be removed using a soft bristle brush and warm water, taking care not to damage the roller surfaces.

CAUTION

To prevent a reduction in the quality of drying, particularly on glossy surfaces, do not use soap solutions or other cleaning agents on the rollers.

- 5 Refit the four-roller assembly and close the dryer.

6.2 Replacing a mains fuse

The mains fuse is located directly above the mains cable entry to the dryer.

- 1 Isolate the dryer from the electrical mains supply (see section 5).
- 2 Remove the fuseholder by turning it anti-clockwise.
- 3 Replace the fuse with an equivalent 8 amp fuse.
- 4 Refit the fuseholder.

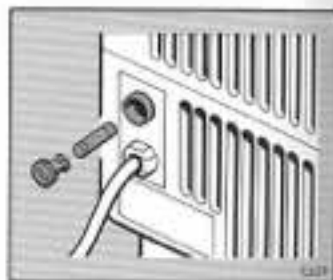

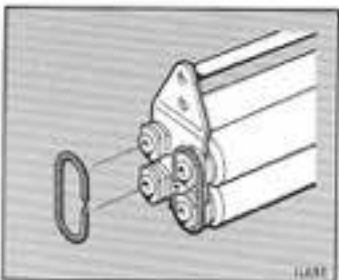
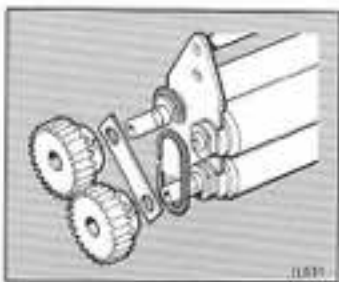

6.3 Replacing a roller tension spring

Roller tension springs are fitted on the four-roller assembly only. Springs are fitted to both ends of the roller pairs.

- 1 Isolate the dryer from the electrical mains supply (see section 5).
- 2 Press the release button and open the dryer until the lid is held securely by the restraining arm.
- 3 Remove the four-roller assembly (see figure 3.1).
- 4 To remove a left hand tension spring, release the socket set screws and remove the gears and locating plate as shown.
- 5 Unhook and remove the spring from the end of the roller pair.
- 6 Fit a replacement spring around the roller bearings, as shown.
- 7 Refit the locating plate and gears. Secure each gear by tightening the socket set screw against the flat on the roller shaft.
- 8 To remove a right hand tension spring, carry out operations 5 and 6 above.
- 9 Refit the roller assembly, and close the dryer.

6.4 Removing rear rollers/adjusting print exit guide

See figure 6.1.

The gap between the print exit guide and the rear upper roller is critical to ensure correct paper transport through the dryer. Initially this gap is factory set. Under normal operating conditions, the print exit guide must not be moved.

If, for any reason, the rear lower roller needs to be removed, the print exit guide must first be moved to clear the way for the roller. This means that, when the rollers are replaced, the gap must be reset as accurately as possible. To help with this operation, the print exit guide has an alignment mark at each end as shown in detail A.

To remove the rear rollers, proceed as follows:

WARNING

This operation requires access to the electrical compartment. Please refer to item 9 in Safety Precautions at the front of this manual.

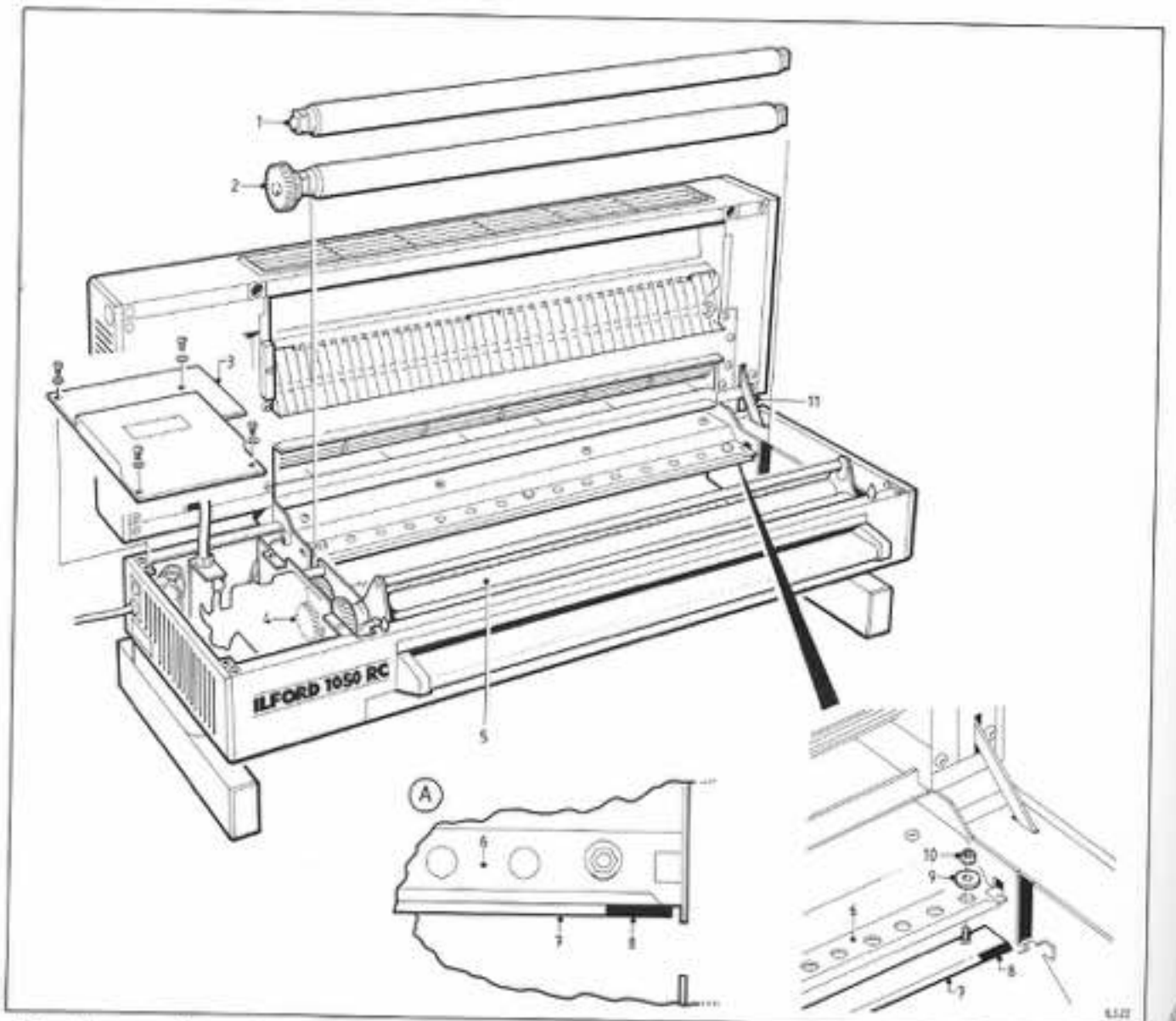

Adjusting print exit guide

Figure 6.1

Figure 6.1

- 1 Upper roller, rear
- 2 Lower roller, rear
- 3 Lower cover, left hand
- 4 Idler gear
- 5 Front roller assembly
- 6 Ventilation grille
- 7 Print exit guide
- 8 Alignment mark
- 9 Washer
- 10 Nut
- 11 Restraining arm

- 1 Isolate the dryer from the electrical mains supply (see section 5).
- 2 Press the release button and open the dryer until the lid is held securely by the restraining arm.
- 3 Release the four screws and remove the lower, left hand cover.
- 4 Carefully remove the upper roller complete with bearings.

Carry out the following operations only if the lower roller is to be removed.

- 5 Slacken the four nuts securing the print exit guide to the ventilation grille and push the exit guide towards the rear of the dryer.
- 6 Carefully remove the lower roller complete with bearings and roller drive gear.

To replace the rear rollers, proceed as follows:

Note

Carry out operations 1, 2, 3, 7 and 8 only if the lower roller is being replaced.

- 1 Ensure the print exit guide is pushed towards the rear of the dryer and is not obstructing the lower roller.
- 2 Replace the lower roller complete with bearings. Ensure the roller drive gear meshes with the idler gear.
- 3 Carefully move the print exit guide towards the upper roller until the rear edge of the mark at each end of the guide is aligned with the front edge of the ventilation grille. Tighten the nuts securing the guide to the ventilation grille. Check the alignment is correct as shown in detail A.
- 4 Replace the upper roller complete with bearings.
- 5 Refit the lower left hand cover. Secure the cover with the four screws and washers.
- 6 Close the dryer.
- 7 Switch the dryer on (see section 4).
- 8 When the dryer is ready, feed a number of wet sheets through, ensuring they exit the dryer without obstruction. If the sheets do not exit correctly, isolate the dryer from the electrical mains supply and check the alignment of the print exit guide. Re-adjust the guide if necessary.

7

FAULT FINDING

This section provides a list of checks to make should there be any problems with the dryer. If the problem persists, contact your nearest ILFORD selling company, the address of which can be found on the back cover of this manual.

CAUTION

If in doubt about carrying out any of the checks, consult a competent engineer. Any further repair work carried out by unqualified personnel will invalidate any guarantees applicable to the equipment.

7.1 Safety feature

An interlock switches off the fan motor, drive motor and heaters if the dryer lid is raised.

Symptom	Possible cause and recommended action
1 Scratches on prints	<p>Sheet fed upside down Feed sheets emulsion side up.</p> <p>Prints pulled from the exit rollers Leave prints to emerge fully from the dryer before handling them.</p> <p>Dirty paper guides Remove roller assemblies and inspect guides (see figure 3.1). Clean guides as necessary.</p> <p>Dirty feed tray Clean feed tray (see figure 3.1).</p> <p>Paper guides bent Contact your nearest ILFORD selling company.</p>
2 Wet or damp prints	<p>Dryer temperature low Adjust temperature control.</p> <p>Faulty heater element Contact your nearest ILFORD selling company.</p> <p>Rollers operating incorrectly Replace any damaged or missing roller tension springs (see section 6.3). Clean rollers (see section 6.1). Ensure the yellow transit wedges have been removed (see section 3.4).</p>
3 Imperfect gloss on glossy prints	<p>Dryer temperature low Adjust temperature control.</p> <p>Prints not fully wetted before drying Ensure prints are completely immersed in the wet print dish before drying.</p>
4 Excessive curl on prints	<p>Dryer temperature high Adjust temperature control.</p> <p>Dryer fan impeded Remove any obstruction from dryer air grille. Observe installation procedure detailed in section 3.</p>

Symptom	Possible cause and recommended action
5 Surface blistering on print	<p>Dryer temperature high Adjust temperature control.</p> <p>Rollers operating incorrectly See symptom 2.</p>
6 Glossy patches on matt or pearl surfaces	<p>Dryer temperature high Adjust temperature control.</p>
7 Dull patches on surface of dried prints	<p>Dirty front roller assembly Clean front roller assembly (see section 6.1).</p>
8 Dryer heaters and/or fan fail to operate	<p>Dryer not switched on or plugged in Connect dryer to electrical supply and turn dryer control to 'run'.</p> <p>Dryer control set to 'rundown' Turn dryer control to 'run'.</p> <p>Dryer lid not closed correctly Ensure lid is closed and locked.</p> <p>Dryer mains fuse blown Replace mains fuse (see section 6.2).</p> <p>Faulty heater element See symptom 2.</p>
9 Print fails to emerge	<p>Paper sheet too small Switch dryer off. Retrieve sheet. Sheets must be at least 12.7cm (5 inches) long.</p> <p>Damaged sheet Switch dryer off. Retrieve sheet.</p> <p>Rollers operating incorrectly Switch dryer off. Retrieve sheet. See symptom 2.</p> <p>Paper guides bent Switch dryer off. Retrieve sheet. See symptom 1.</p> <p>Exit guide misaligned Check alignment of exit guide. Adjust if necessary (see section 6.4).</p>

8 SPECIFICATION

PERFORMANCE DATA

Dryer speed	100cm/min (39.4 inches/min) at rated voltage
Maximum output	480 20.3x25.4cm (8x10 inches) per hour at the specified dryer speed
Warm up time	Typically 120 seconds, varying with ambient temperature
Access time	Typically 20 seconds for a 20.3x25.4cm (8x10 inches) sheet with the dryer operating at the specified speed

PRINT SIZES ACCEPTED

Maximum width	50.8cm (20 inches)
Minimum length	12.7cm (5 inches)

DRYER DIMENSIONS

Height	273mm (10.9 inches)
Width	755mm (29.7 inches)
Length	615mm (24.2 inches) including print receive tray

WEIGHT

Dryer	20kg (44 lbs)
-------	---------------

ELECTRICAL

Heaters	Two 750W at 220/240V	
Voltage	220V	or 240V
Frequency	50Hz	50Hz
Phase	Single	Single
Maximum current	6 amp	6.6 amp
Power consumption	1300W	1600W
Fuse rating	8 amp	8 amp

Constant improvements in ILFORD products mean that changes in design or specification may occur from time to time. It will not always be possible to amend instructions at the same time, and the right to alter the design and specification of the equipment without prior notice is accordingly reserved.

The ILFORD 1050RC dryer is protected by world patents.

Australia

ILFORD PHOTO (Australia) Pty Ltd
PO Box 144
Mt Waverley
3149 Victoria

Belgium

SA ILFORD PHOTO NV
Kazernenlaan 39
B-1040 Brussel

Canada

ILFORD PHOTO (Canada) Limited
2751 John Street
Markham
Ontario
L3R 2Y8

Denmark

ILFORD PHOTO A/S
Gadelandet 18
DK-2700 Brønshøj

France

ILFORD PHOTO SA
BP 336
Chemin de la Fauillouse
F-69802 Saint-Priest
Cedex

Germany

ILFORD PHOTO GmbH
Postfach 124
D-6078 Neu-Isenburg

Holland

ILFORD PHOTO BV
Jan Rebelstraat 5
Postbus 9040
NL-1006 AA Amsterdam

Italy

ILFORD PHOTO SpA
Origgio (Va)
Casella Postale 77
I-21047 Sarona

Sweden

ILFORD PHOTO AB
Box 3052
S-400 10 Göteborg

Switzerland

ILFORD PHOTO AG/SA
Rue de l'industrie 15
CH-1700 Fribourg 5

United Kingdom

ILFORD PHOTO Company
14-22 Tottenham Street
GB-London W1P 0AH

USA

ILFORD PHOTO Corporation
West 70 Century Road
PO Box 288
Paramus
New Jersey 07653

If your country is not
shown here,
please contact:
ILFORD PHOTO International
ILFORD Limited
14-22 Tottenham Street
GB-London W1P 0AH
England

OPERATING

PROCESSING

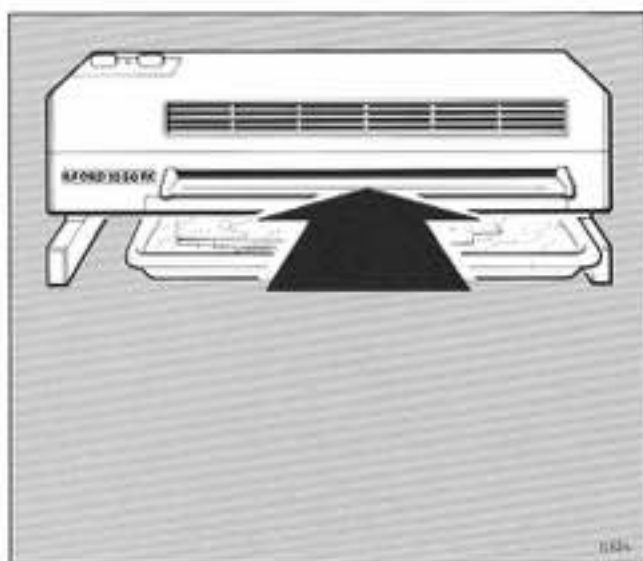
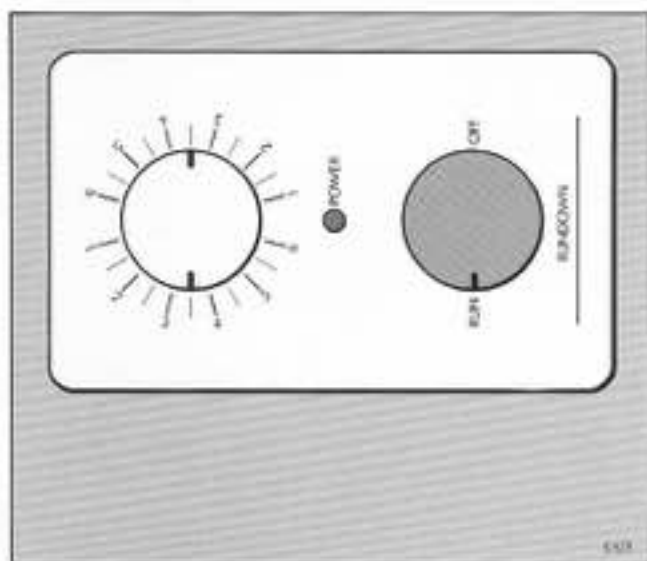

1 Turn dryer control to 'run'.

3 Feed sheets (notes 3, 4, 5 and 6).

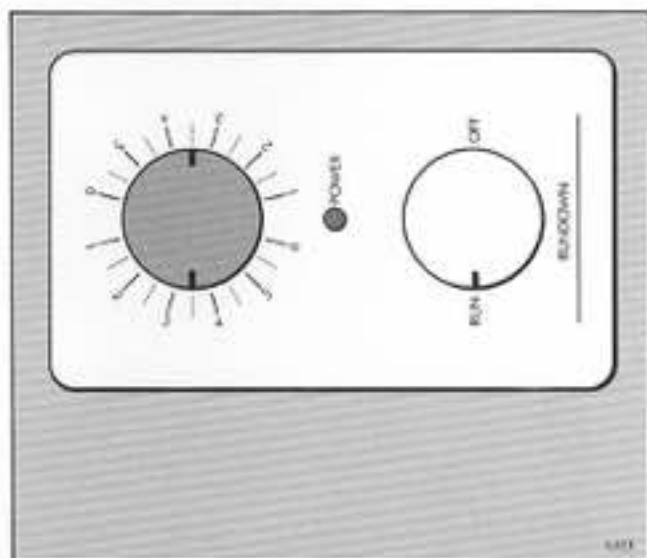

IMPORTANT NOTES

- 1 Try mid-point temperature setting first.
- 2 Allow 2 minutes for dryer to warm up.
- 3 Feed sheets emulsion side up.
- 4 Feed prints squarely.
- 5 Feed small prints with short edge leading.
- 6 Allow 2 seconds delay between prints.
- 7 Allow dryer to cool for 2 minutes.

SWITCHING OFF

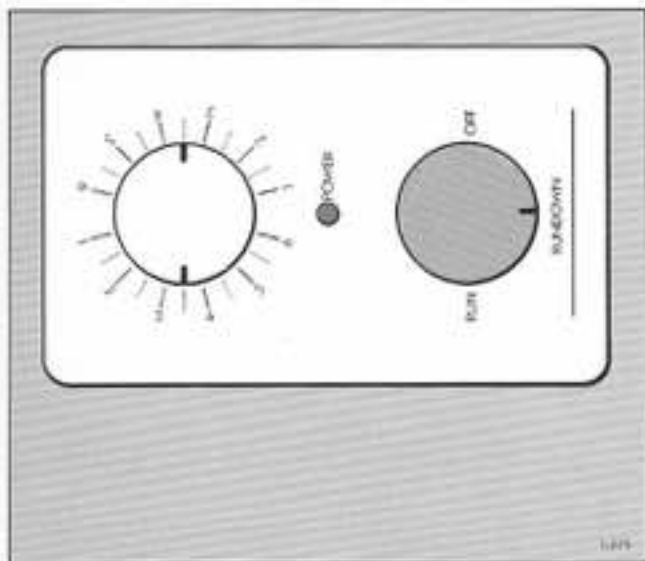

- 1 Turn dryer control to 'rundown' (note 7).

